



PTS Products, Inc.

Contract Design, Assembly and Manufacturing

Systems Design and Programming
Control Panels and Boxes
Wire Harnesses and Electronic Assemblies



Contract Design, Assembly and Manufacturing

- » Total Solution Provider
- » ISO 9001 Certified
- » UL 508A Certified
- » Service focused

At PTS Products our total solution approach means that we can support your manufacturing process from design thru documentation, assembly and final testing. This frees your valuable resources to be focused on your core business.

As an ISO 9001 certified vendor, you can be assured that you will always receive consistent, high quality products and sub - assemblies.

As a UL508A certified electrical panel builder, PTS Products meets or exceeds the certification requirements for safety.

We specialize in low to mid sized production runs.

Systems Design and Programming

PTS has extensive experience in control system design and programming. We can write in many of today's most popular languages and can provide:

- Schematics
- Bills of Materials (BOM's)
- Print Packages
- PLC Programming
- Motion Control
- HMI Programming (xycom Proface, C-more)
- AutoCAD Electrical
- AB Panelview
- AB RSlogix 500
- AB RSlogix 5000
- GE Cimplicity Machine Edition

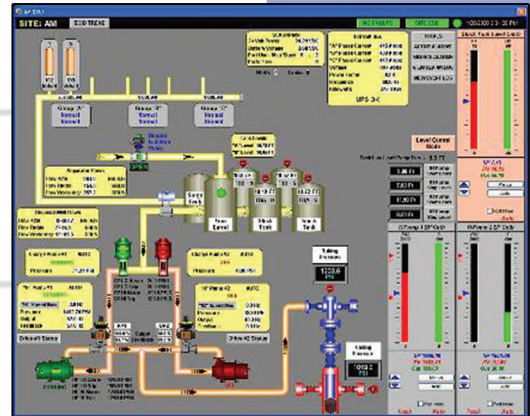

Control Panels and Boxes

PTS Products, Inc. is a UL508A certified electrical panel builder with staff to custom build control panels for many industries. Our machine shop can modify electrical enclosures with CNC milling machines and other automated hole making equipment.

- UL 508A Certified, Including UL,cUL & CSA
- Enclosure Modifications, including labeling, marking, logo application, and custom paint
- Panels built from schematics
- Cabinet Wiring
- Relay Panels
- Process Control Panels
- Junction/Termination Boxes
- Pneumatic Panels
- Analyzer Panels
- VFD Panels
- PLC Panels

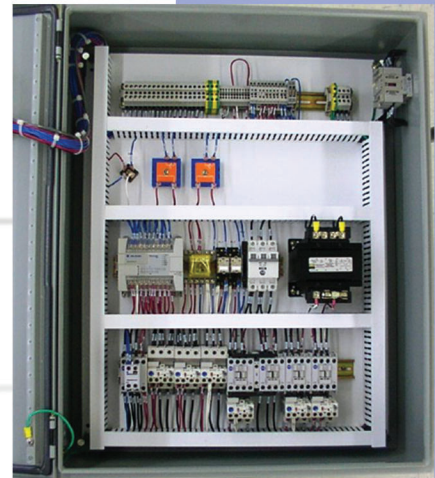

Wire Harnesses and Electronic Assemblies

We specialize in low to medium volume runs of a diverse range of standard and custom wire harnesses and electronic assemblies including:

- Electrical cable & wire harnesses
- Electro-mechanical wire harnesses
- Battery and power supply wire harness assemblies
- Multi-conductor cable harnesses
- Industrial Wiring Harnesses
- Medical Equipment Cables & Harnesses
- Custom Video Cables and Harnesses
- Passive component-to-wire applications
- Switch-to-wire applications
- Printed Circuit Board Assemblies
- Control and panel wiring assemblies
- Custom Spec Cables & Harnesses
- Alarm / Surveillance and Security Wire Harnesses

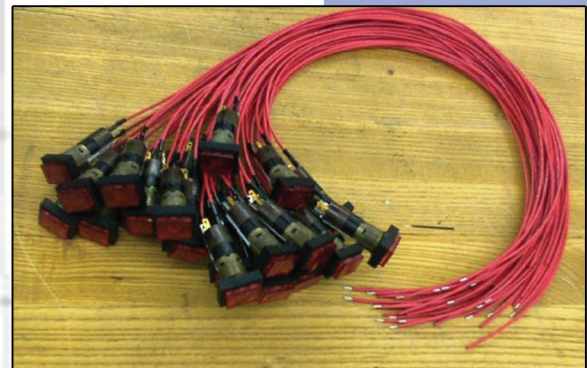

Represented By:

MYNER GROUP

952.471.1226

mynergroupp.com



PTS Products, Inc.

PTS Products, Inc. · 2321 Commerce Blvd. · Mound, MN 55364 · Ph: 952.472.3677 · Fax: 952.472.0407